

HOFMANN®



geodyna 8200p

Spare Parts List

Conway Produced

07/2020 - Present



BOM EEWB766BEA Geodyna 8200p

Part Number	Quantity	Description
EAA0394G59A	1	Final Assy Comp
ZEEWB766B9	1	Technical Document Geo 8200-2P
EAK0309J30A	1	Monitor 19" W/Touchscreen
EAA0384G66A	1	Complete Wheelguard 42"
EAX0039J01A	1	Cord Power, 230V
EAW0286G19A	1	Cord Power IEC 320 M/F
3-02615A	1	Drive-USB Flash 4 Gb
6-18522A	1	Cable USB 2.0 A-B 3M
6-18622A	1	Cable Audio 3.5 Jack 3M
6-12722A	1	VGA Cable 3M
EAM0003J69A	1	Cone (3.42 - 5.25)
EAC0058D68A	1	Spacer, 29660
EAA0283D11A	1	Clamping Device
EAL0442G45A	1	Decal Geo 8200P
EAL0349G56A	1	Adhesive Label 125 x 68
EAL0341J97A	1	Label-Balancer Warning Side
8-40162A	1	Label Stop
EAL0424G39A	1	Pedal Stop Removal Label
EAL0462G77A	1	Label Scanning Glass Cleaning
EAL0462G78A	1	Label Brake Pedal Cleaning
EAL0343J76B	1	Serial Label Document
EAL0341J70A	1	Label-Laser Aperture
EAL0341J71A	1	Label-Cfr Certification
EAL0412G63A	1	Label-2M Class Laser 36018
EAL0341J63A	1	Label-Patent
EAL0342P04A	1	Label,Safety, "Goggles"
EAL0341J97A	1	Label-Balancer Warning Side
EAL0420J58A	1	Label-Max Wheel Dia

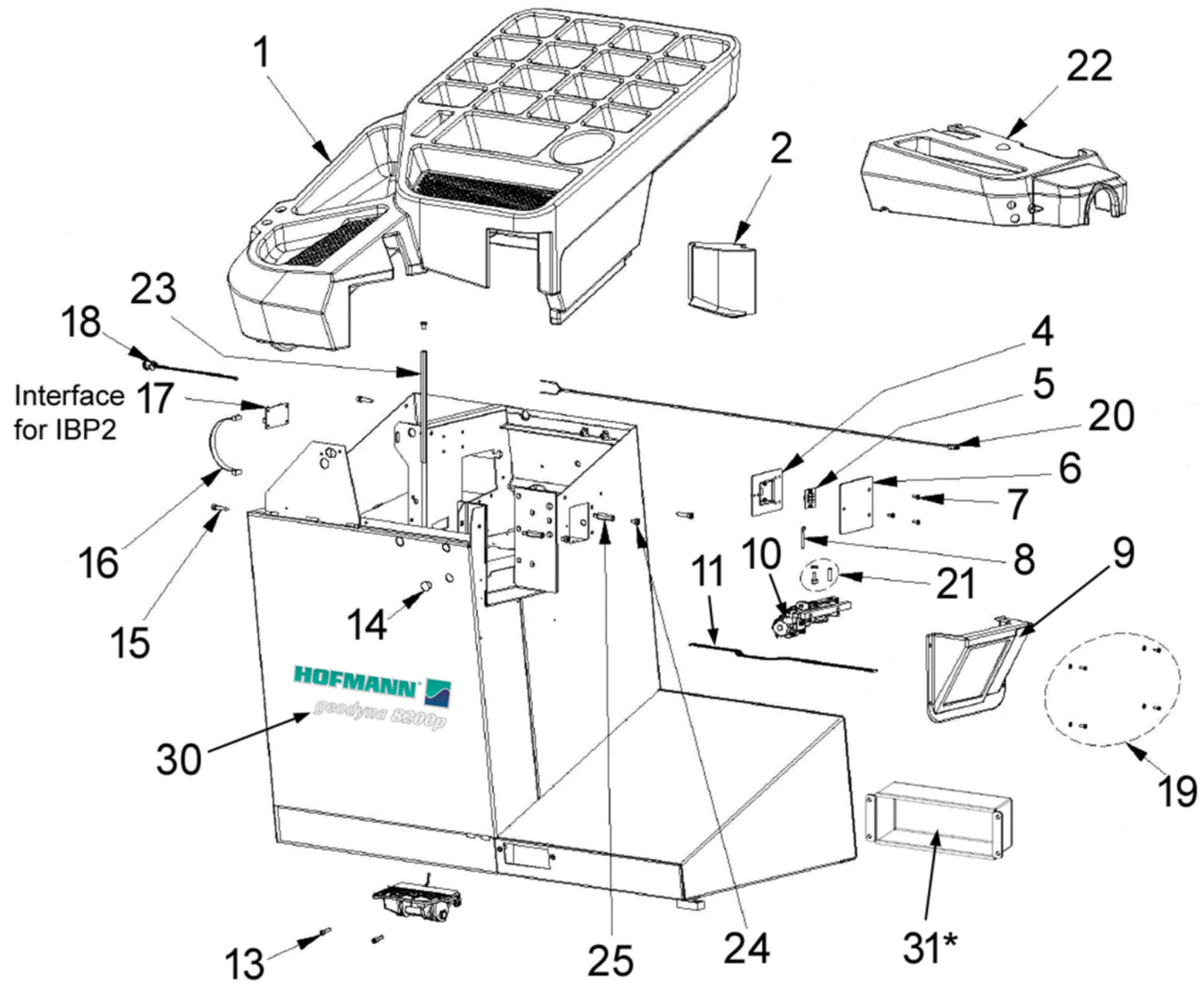

Ref	Qty	Part Number	Description
1	1	EAM0123G61A	Machined Weight Tray Cabinet L3
2	1	EAC0103G93A	Cover For Weight Tray L3
4	1	EAC0103G85A	Led Lighting Support Support
5	1	EAP0290G30A	Led Lamp Board
6	1	EAM0074G23A	Protective Screen
7	3	1-22623A	Screw, Phil Pan H.Tapp.
8	1	EAW0282G98A	Led Lamp Cable
9	1	EAA0357G43A	Inside Laser Protection Complete
10	1	EAA0394G27A	Inside Scanner
11	1	6-01329A	Ffc Cable L=720mm 18 Ways
13	2	1-16409	Screw
14	7	EAC0060G00A	Vibratory System Holes
15	3	1-11324A	Self Tapping Screw
16	1	EAW0283G11A	Interface IBP2 Cable
17	1	EAP0290G40A	Interface For IBP2
18	1	EAW0283G09A	Stop Button Cable
19	1	EAK0315G61A	Screw Kit For Cover
20	1	EAW0283G12A	Cable For Switching On Lamp
21	1	EAK0315G62A	Kit Viti Scanner
22	1	EAM0123G62A	Machined Cover For Vibratory System
23	1	EAM0116G57A	Hexagonal Spacer
24	3	1-31406A	Screw
25	2	1-01915A	Hexagonal spacer
30	1	EAL0442G45A	Decal Geo 8200p
31*	1	EAA0508G89A	Brake Pedal Cover
*Only used with EAA0508G82B Pedal Assembly			

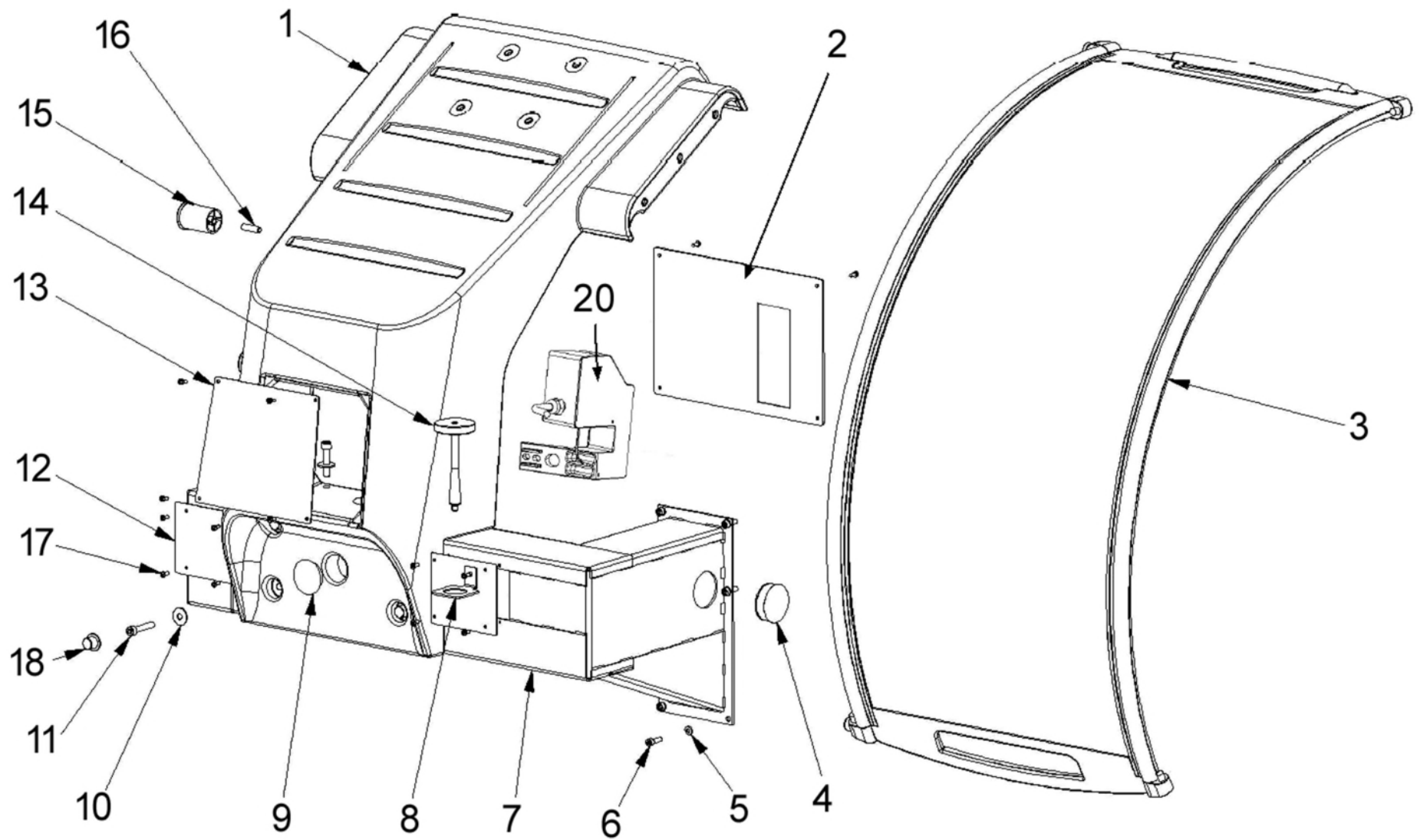

Ref	Qty	Part Number	Description
1	1	EAM0116G34A	Cabinet L3 Wheelguard Support
2	1	EAM0101G03A	Cover For Rear Scanner
3	1	EAA0384G66A	Complete Wheelguard 42"
4	1	1-10576A	Black Cov. Cap For Sheetmetal
5	6	1-2746	Washer
6	6	1-16409A	Screw Tcei 6 x 20
7	1	EAS2134G99AC	Wheel-Guard Support
8	1	EAS2041G56AC	Calibr.Weight Bracket
9	1	1-3176	Dome Hole Plug
10	6	1-17841A	Washer D. 8 x 24, Blk
11	6	1-30109A	Screw
12	2	EAS2139G85AC	Rear Cover
13	1	EAS2139G84AC	Rear Cover
14	1	EAM0005D40A	Calibration Weight
15	4	EAC0058D54A	Conical Bolt
16	4	1-12010	Set Screw
17	1	EAK0329G16A	Kit Screws
18	4	1-14576A	Plug
20	1	EAA0409G27A	Assy Scanner 8200

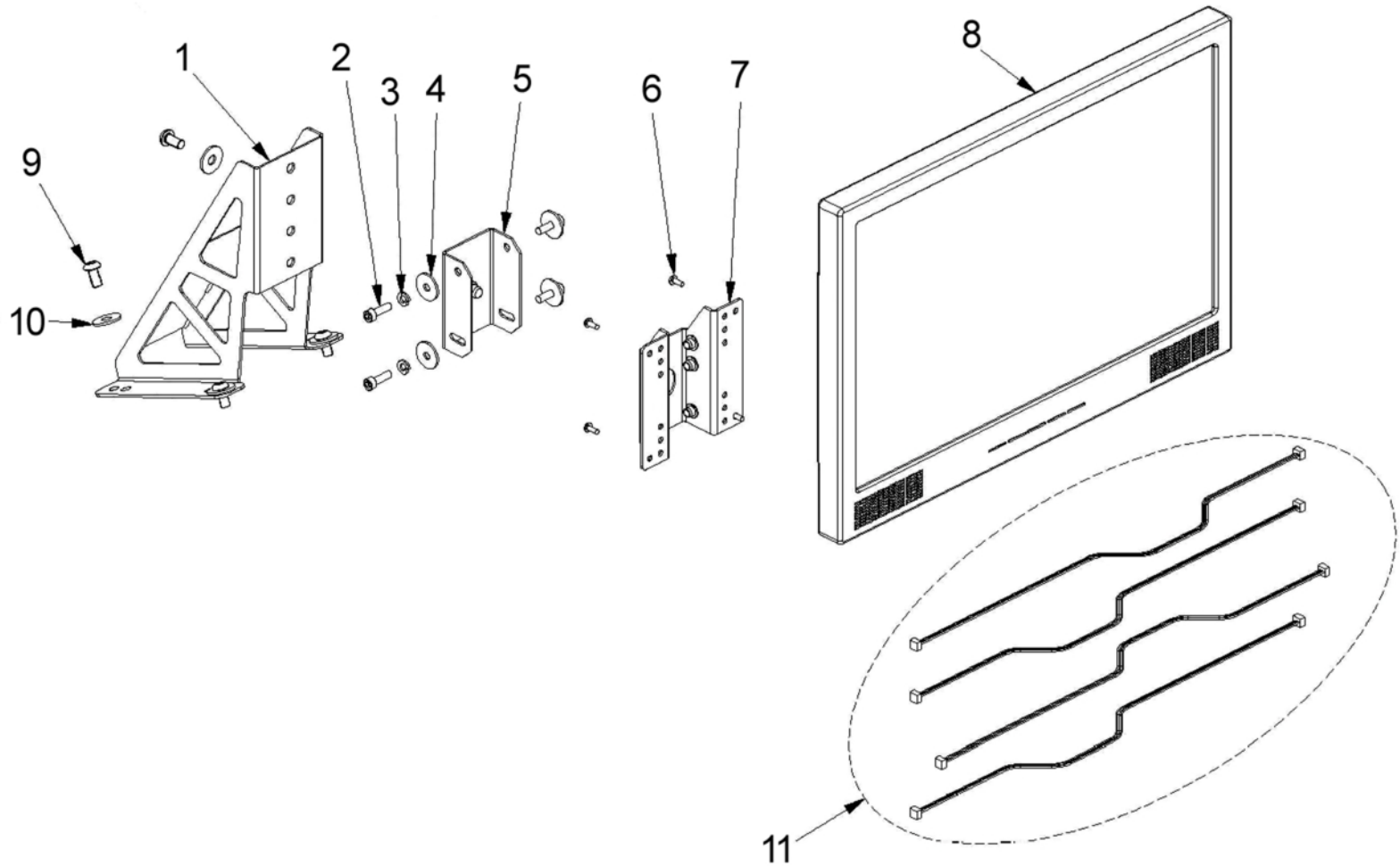

Part Number	Description	Ref	Qty	Part Number	Description
EAS2152G18AC	Monitor Support	7	1	EAA0345G43AC	Vesa Coupling Unit
1-16409A	Screw Tcei 6 x 20	8	1	3-08108A	19" Wide Monitor
1-2746	Washer	9	5	1-9902A	Screw
1-22941A	Washer	10	5	1-17841A	Washer D. 8 x 24
EAA0458G07AC	Assy Monitor Interface	11	1	EAK0315G98A	Cables Kit
1-54310A	Set Screw				
1-13533A	Nut				

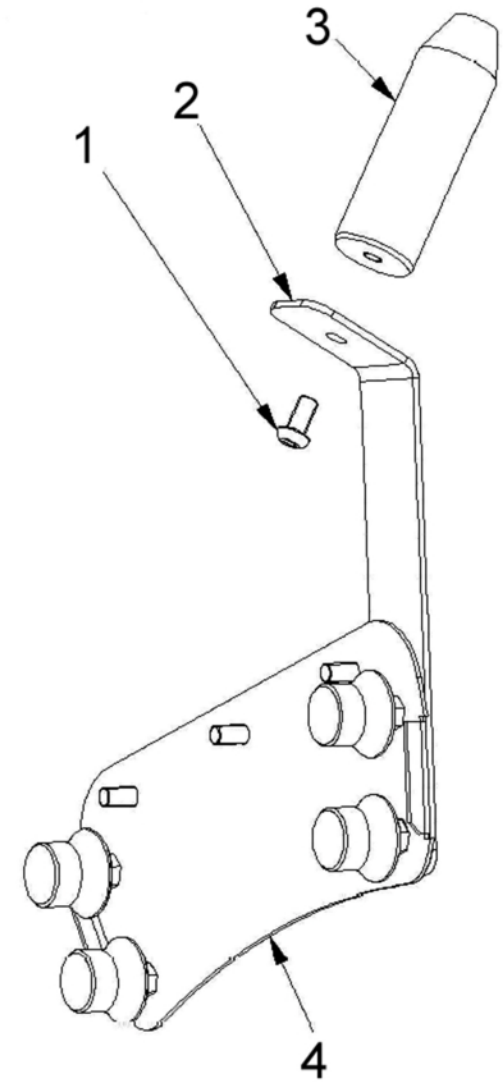
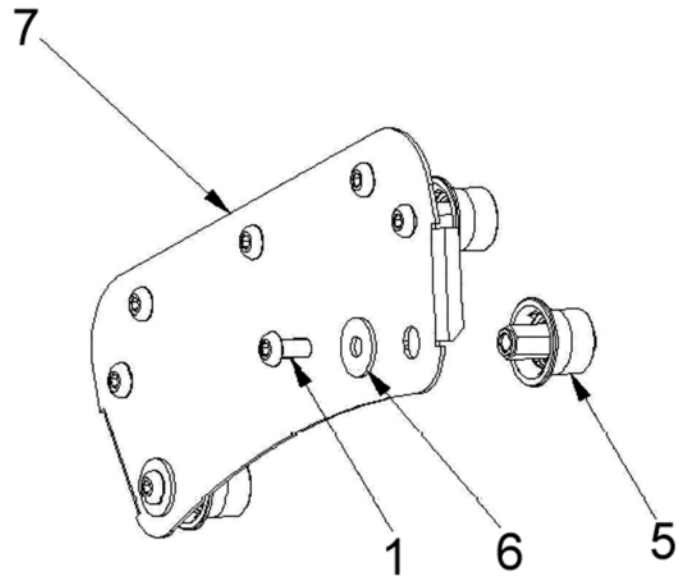

Ref	Qty	Part Number	Description	Ref	Qty	Part Number	Description
1	15	1-9902A	Screw	5	8	EAA0364G49A	Complete Unified Roller
2	1	EAS2152G85AC	Angular Support	6	4	1-17841A	Washer D. 8 x 24, Blk
3	1	EAM0086G20A	Taper Shank Plastic	7	1	EAS2187G97AC	Side Wall Sheetmetal
4	1	EAS2187G98AC	Side Wall Sheetmetal	NS	8	1-35841A	Shim Ring 11.2 x 17 x 0.5

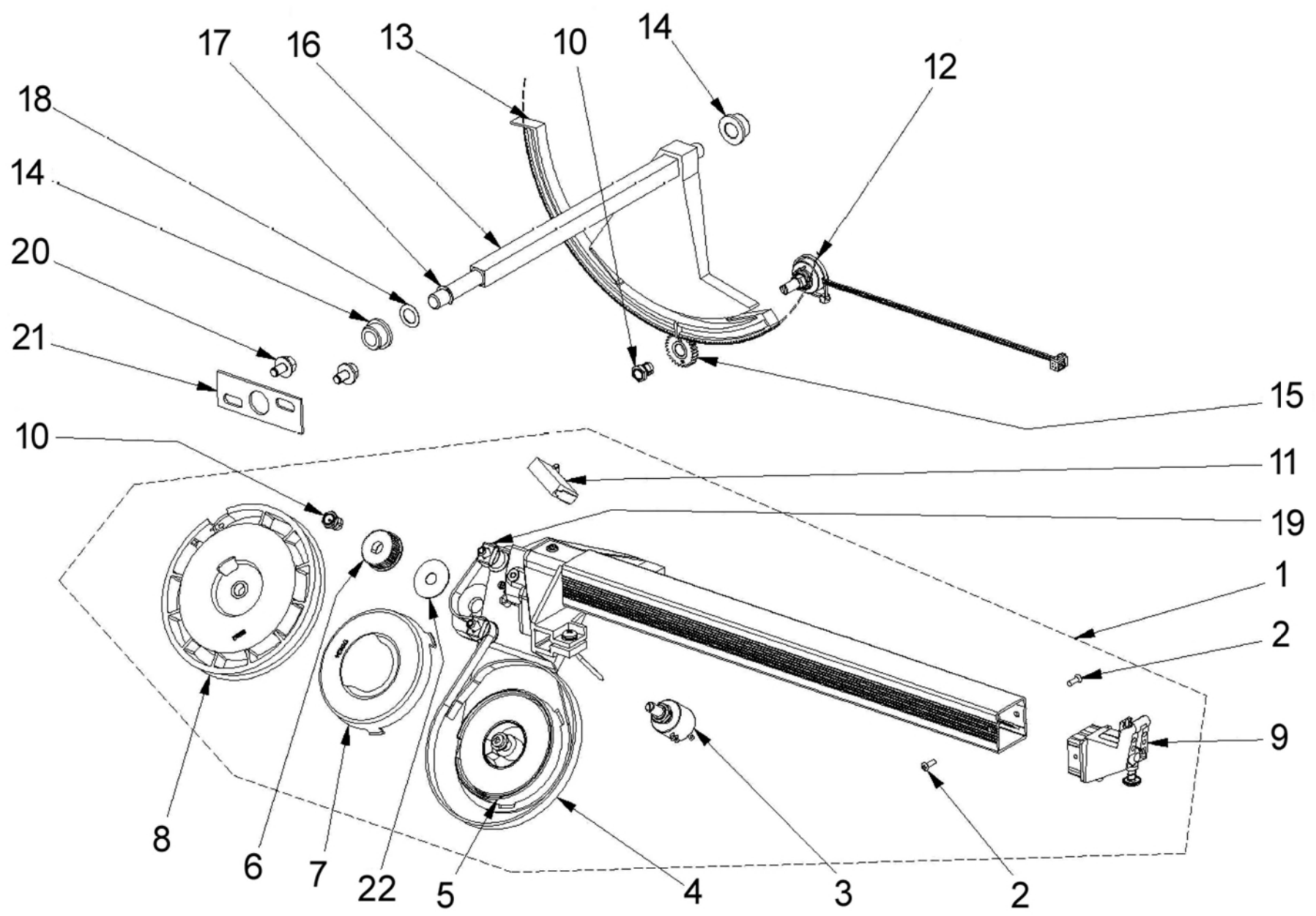

Ref	Qty	Part Number	Description
1	1	EAA0410G82A	Geodata 4 Gauge Unit
2	2	1-23123A	Self Tapping Screw
3	1	EAA0410G85A	Wired Multiturn Potentiometer
4	1	EAA0410G83A	Toothed Belt
5	1	1-03967A	Spiral Spring
5	1	1-03967A	Spiral Spring
5	1	1-03967A	Spiral Spring
6	1	EAC0127G42A	Synchronous Pulley Z=50
7	1	EAC0058D58A	Safety Cover
8	1	EAC0058D06A	Return Pulley
9	1	EAA0357G97A	Geodata Applicator Unit
10	2	2-07657A	Clamping Device
11	1	2-09437A	Cutout Blade Relay
12	1	EAA0266D20A	Potentiometer Unit With Nut
13	1	EAC0103G97A	Tooth Segment
14	2	1-06565A	Bushing
15	1	EAC0058D13A	Wheel Gear
16	1	EAM0055G61A	Geodata Pin
17	1	1-19377A	Circlip
18	1	1-20641A	Shim Adjustment Washer
19	2	EAM0005D60A	Roller
20	2	1-07024A	Screw
21	1	EAS2058D01A	Positioning Plate
22	1	EAM0192G66A	Washer

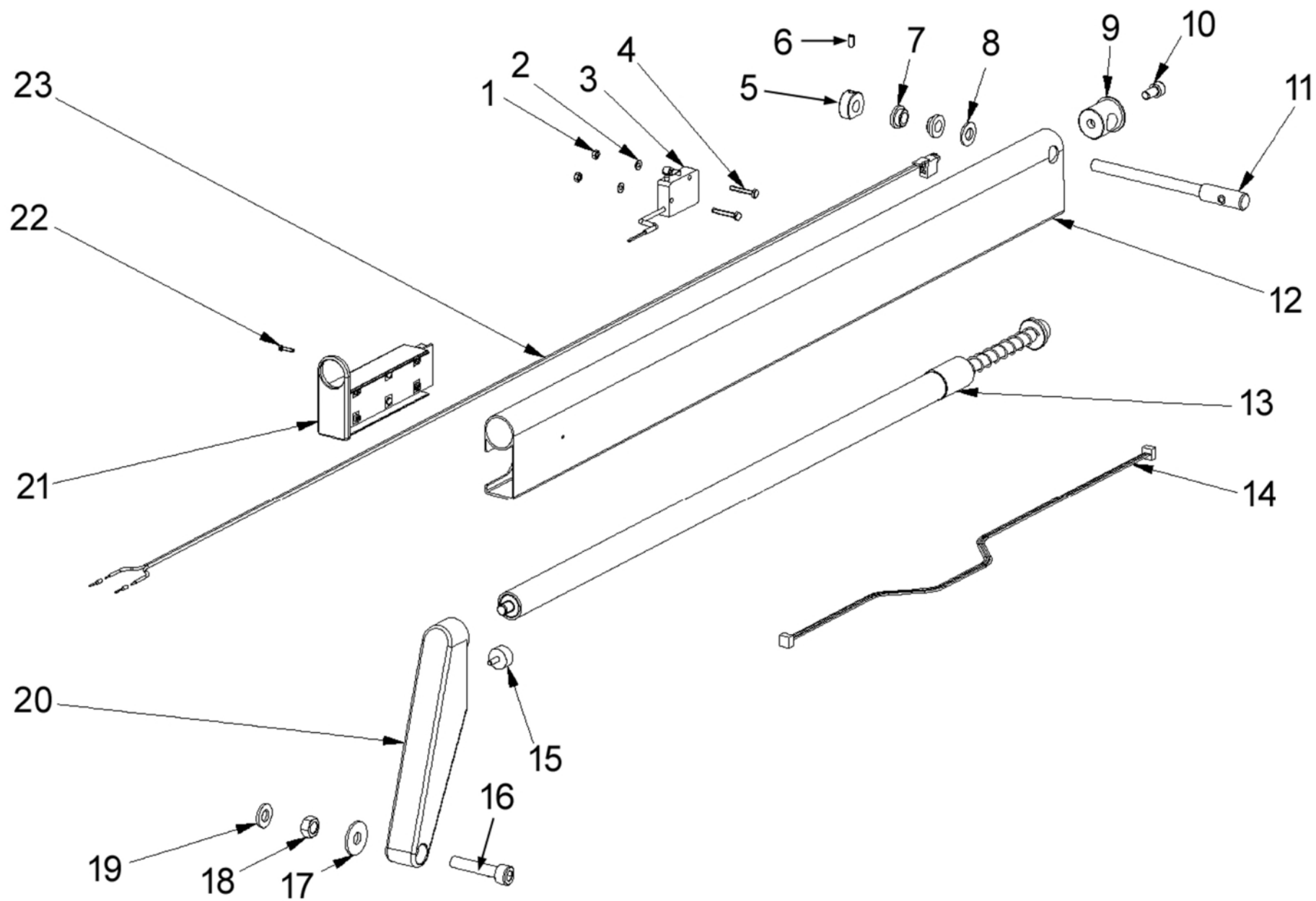

Ref	Qty	Part Number	Description
1	2	1-11233	Nut - M3
2	2	1-9541	Washer Plain
3	1	EAW0233J08A	Wheelguard Switch
4	2	1-26901	Screw,Hex Head
5	1	EAM0021D12A	Switching Ring
6	1	1-38910	Screw
7	2	1-06065A	Bearing Bush
8	1	1-10041	Washer D.8
9	1	EAM0021D08A	Tightening Bolt
10	1	1-16209	Screw Tcei 6 x 12
11	1	EAM0021D11A	Pin
12	1	EAM0093G75A	Anodized Arm
13	1	EAA0283D52A	Wheel Guard Damper
14	1	EAW0277G39A	Ultrasonic Sensor Extension Cable
15	1	8-09318A	Bumper
16	1	1-30109A	Screw
17	1	1-17841A	Washer D. 8 x 24, Blk
18	1	1-11733	Nut M8
19	1	1-10041	Washer D.8
20	1	EAC0103G51A	Joint For Sonar Arm
21	1	EAA0371G27A	Assy Sonar Box
22	1	1-09824A	Screw
23	1	EAW0239D08A	Extension Cable for WG Switch

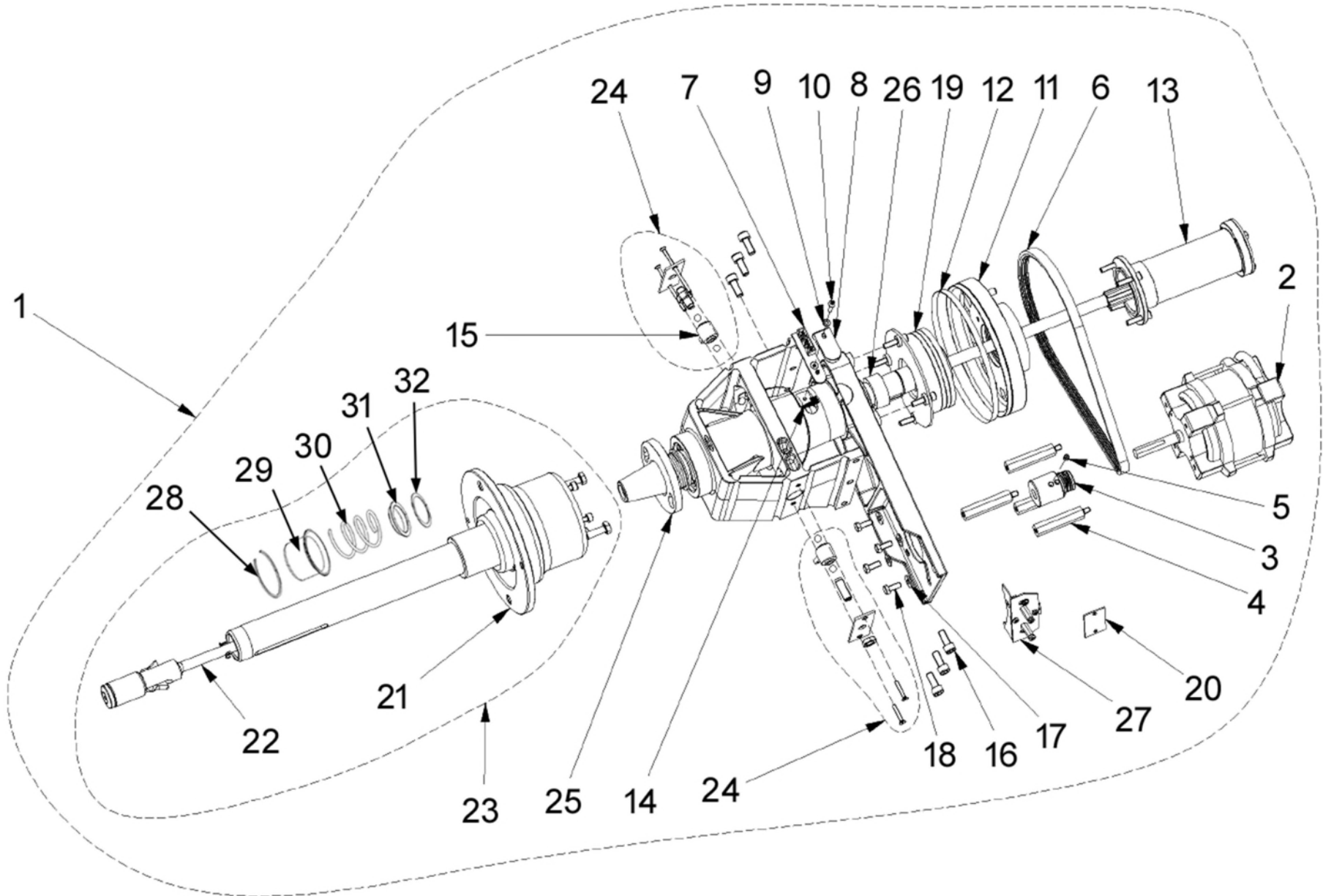

Ref	Qty	Part Number	Description
1	1	EAA0392G39A	Complete Vibratory
2	1	2-59366A	Motor w\Connector
3	1	EAM0005D08A	Motor Pulley
4	4	EAM0061G82A	Unit Motor Spacer
5	1	1-28410	Screw
6	1	8-3531	Belt
7	1	EAA0344G00A	Opto-Electronic Unit
8	1	EAC0094G11A	Encoder Board Protection
9	1	1-9641	Washer
10	1	1-35006A	Screw
11	1	EAM0021D18A	Motor Pulley
12	1	EAM0005D64A	Encoder Bar Code
13	1	EAA0307G36A	Replacement Kit "P"
14	1	EAW0240G67A	Cable Without Temp. Sensor
15	2	EAA0260D59A	Transducer
16	6	1-17709	Screw Tcei 8 x 20 8G
17	4	1-16641A	Washer Plain
18	4	1-46701A	Hex Head Screw
19	1	EAA0307G35A	Brake Disc Repair Kit
20	1	EAP0201D20A	Encoder Board Complete
21	1	EAA0382G01A	Power Clamp Flange L
22	1	EAA0382G02A	Pull-Shaft Complete L
23	1	EAA0384G71A	P-Clamp Flange Complete
24	1	EAA0328G16A	Transducer Fixing Unit
25	1	EAA0307G37A	Bayonet Fitting
26	1	EAM0051G25A	Power Clamp Spacer Ring
27	1	EAK0329G15A	Board Support Kit
28	1	1-13077	Circlip
29	1	EAS2025D14A	spring Guide
30	1	1-07768A	Compression spring
31	1	EAC0058D14A	Spring centering ring
32	1	1-18241A	Washer

Power Clamp Pedal Assembly used up 7/2022 (766GRxxx)

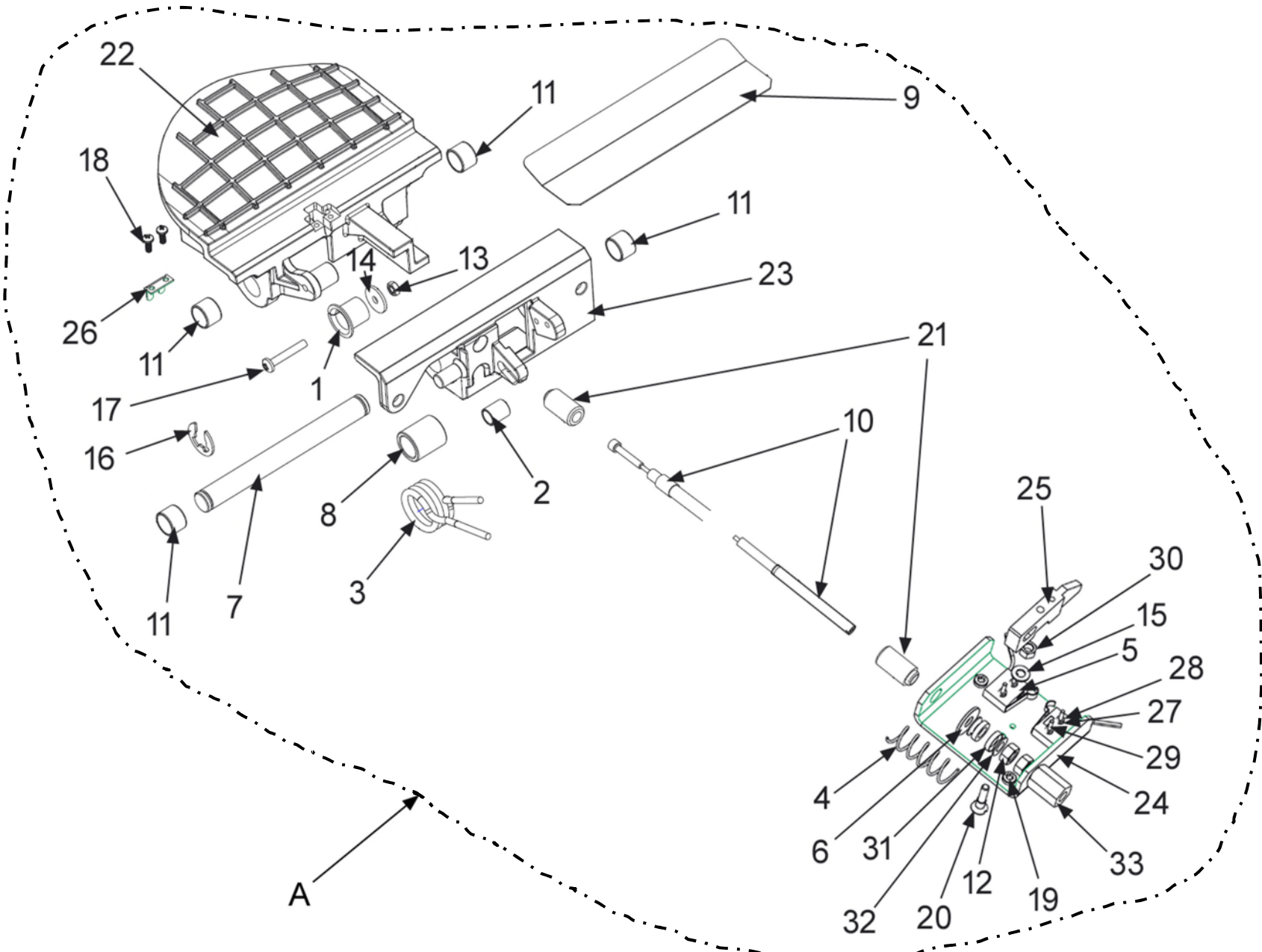

Ref	Qty	Part Number	Description
A	1	EAA0409G98AC	ALU Brake Pedal 2 Switch UL
1	1	EAM0181G49A	Double Shoulder Bushing 12 x 14 x 15
2	1	EAM0181G04A	Spacer With Flange 8.4
3	1	EAM0048G78A	Spring, Pedal Switch
4	1	1-12068A	Compression Spring 1.5 x 13.5 x 45
5	2	2-07661A	Micro Switch with Wires
6	1	1-20041A	Washer - Flat 18mm x 6.5mm x 1.5mm
7	1	EAM0046G39A	Pedal Pin
8	1	EAM0051G96A	Bushing Cent Spring
9	1	EAL0443G72A	Adhesive Pedal
10	1	EAA0344G15A	Cable for Brake Pedal
11	4	1-10165A	Self Bushing PAP1210-P10
12	2	1-11633	Nut M6 x 5.2mm Thk Blk
13	1	1-11433	Nut-M4
14	1	1-22741A	Washer, Plain
15	1	1-36741A	Shim Ring 5 x 10 x 1
16	2	1-18477A	Retaining Ring 10 x 1.2mm
17	1	1-26506A	Screw-Phms M4 x .7mm x 25mm
18	2	1-20504A	Screw - PHM M3 x 8mm
19	2	1-22623A	Self-Tapping Screw TCB
20	1	EAM0153G23A	Pin for Actuator
21	2	EAM0103G42A	Spacer For Brake Cable
22	1	EAM0122G48A	Pedal Machined UL
23	1	EAM0181G72A	Brake Pedal Support Finished
24	1	EAS2128J78A	Microswitch Support
25	1	EAM0153G24A	Actuator
26	1	EAS2128J75A	Cable Stop
27	4	1-1048	Washer-External Shakeproof D2
28	4	1-11033	Nut - Hex, M2
29	4	1-36606A	Screw -M2x 16mm, Pn Head PH Zinc
30	1	1-11533A	Hex Nut M5
31	2	1-36641A	Washer Spherical M6 D
32	2	1-36141A	Washer Spherical M6 C
33	1	EAM0140G21A	Bushing Threaded

Power Clamp Pedal Assembly from 10/2022 (766KRxxx)

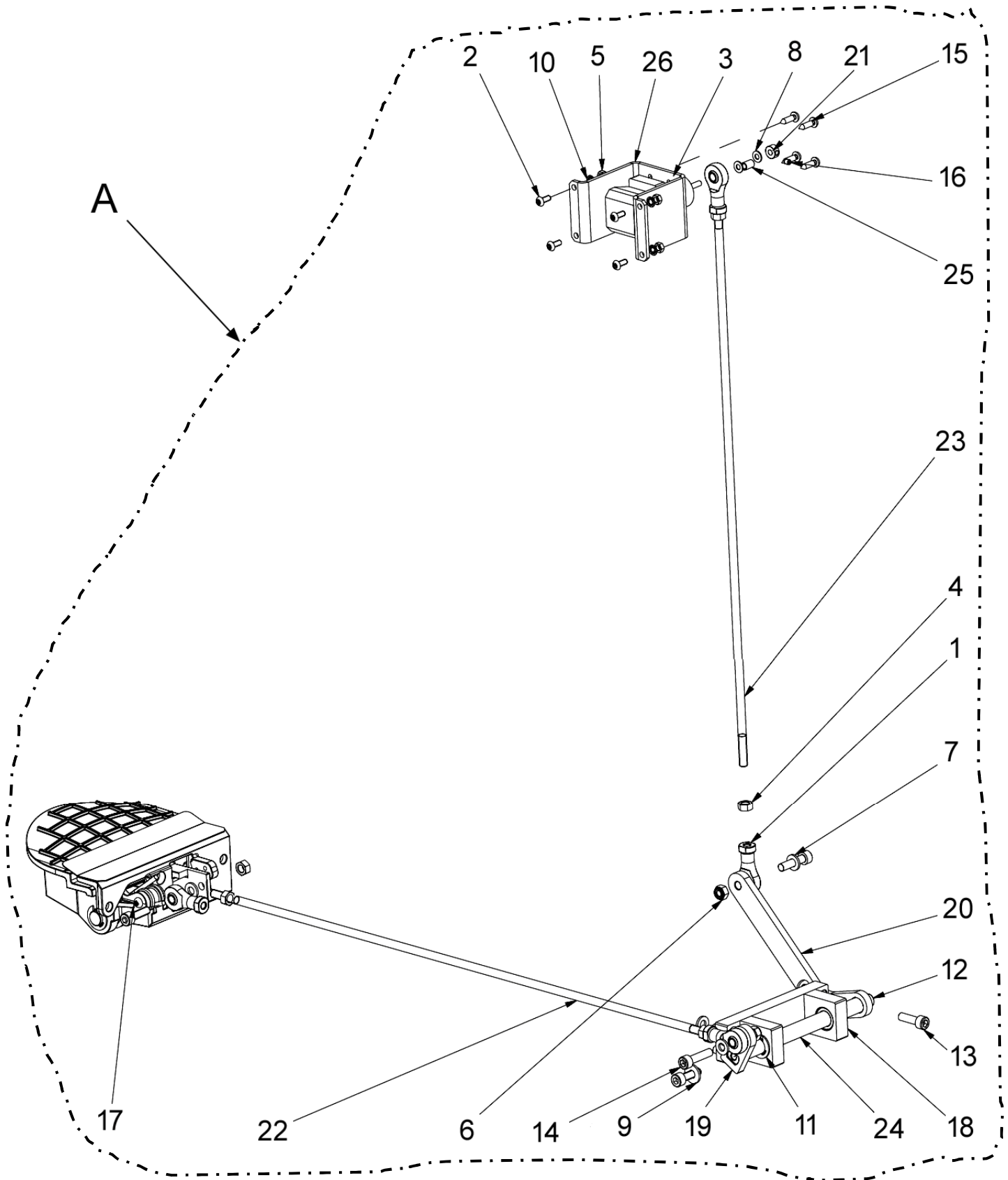

Ref	Qty	Part Number	Description
A	1	EAA0508G82B	Complete Brake pedal assembly
1	4	1-11963A	Rod End Self Lubricating
2	4	1-68209A	Screw M4 x 10
3	1	2-13658A	Joystick, 2 Positions, 48mm Shaft
4	5	1-11633A	Nut-Hex. M6 6S
5	4	1-11433A	Nut, Hex M4
6	2	1-9933	Nut, Prevailing Torque M6
7	9	1-9841	Washer, Plain D6
8	2	1-9641	Plain Washer D4mm
9	2	1-16641	Washer Plain D6mm
10	4	1-05747A	Lockwasher - Internal Tooth - D.4
11	2	1-18477A	Retaining Ring 10 x 1.2mm Thk
12	3	1-16409	Screw - Hex Socket Head Cap
13	4	1-16409A	Screw, Hex Socked Head M6 x 20
14	2	1-16509A1	Screw, Hex Socket Head M6 x 25
15	4	1-18023A	Screw, Selfthread. 8P x 16 Tcb
16	1	1-38610	Screw M4 x 4 Set Cup Zn
17	1	EAA0503G89A	Alu Brake Pedal UI Version
18	1	EAA0508G83B	Shaft Support Assy L Cabinet
19	1	EAM0179G23B	Small Linkage Plate
20	1	EAM0179G25B	Big Linkage Plate
21	1	EAM0180G228	Joystick Connection
22	1	EAM0181G01B	Pulling Bar Low L Cabinet
23	1	EAM01B1G02B	Pulling Bar Upper L Cabinet
24	1	EAM0181G03A	Bearing Shaft L Cabinet
25	1	EAM0181G82A	Joystick Bushing
26	1	EAS2229G22A	Joystick Support

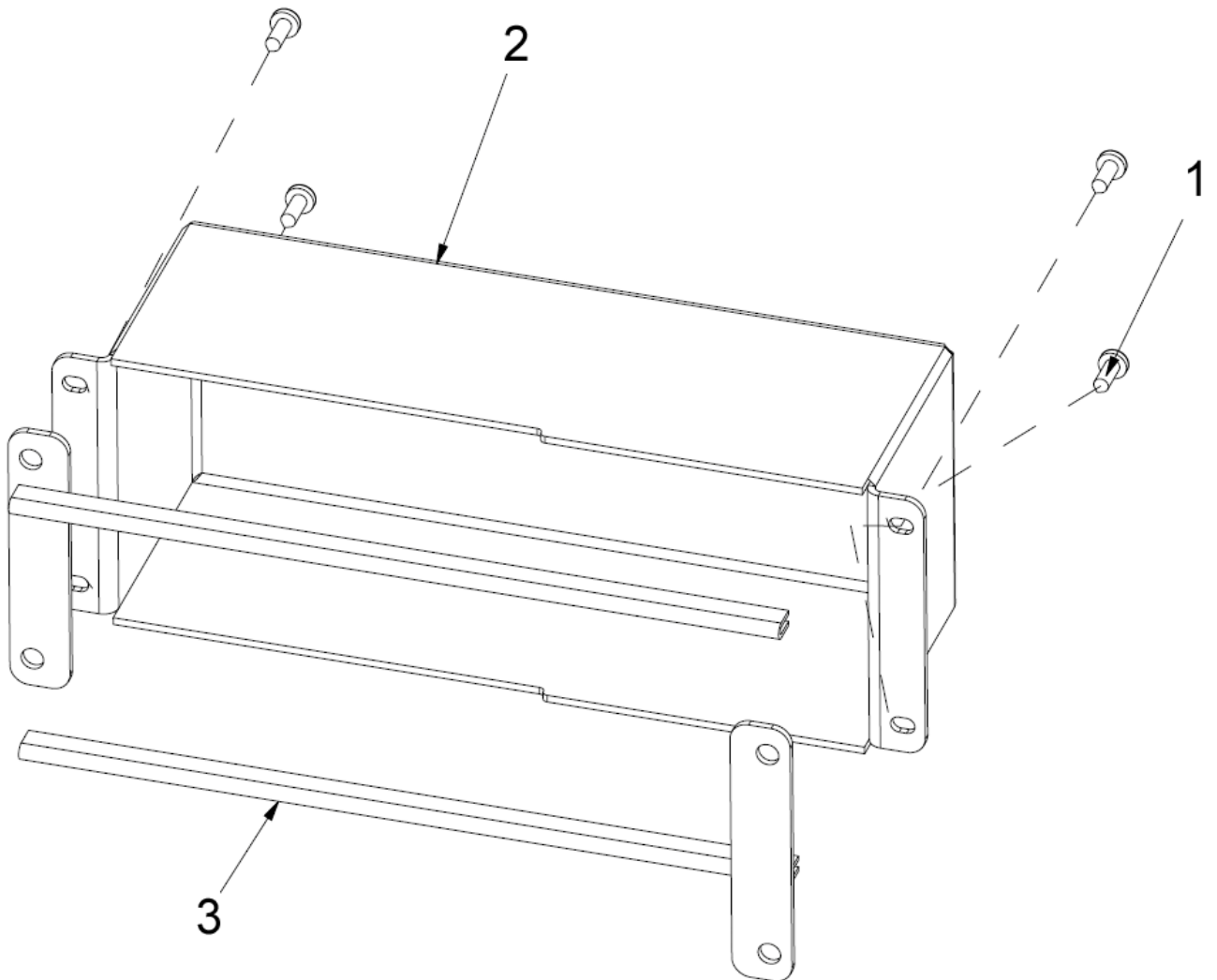

Ref	Qty	Part Number	Description
1	4	1-22623A	Self-Tapping Screw
2	1	EAA0508G91A	Cover
3	2	EAM0181G15A	Rubber Gasket
4	2	EAM0202G86A	Self-Adhesive Sealing

Electronic Box used up to 9/2023 (766JSxxx)

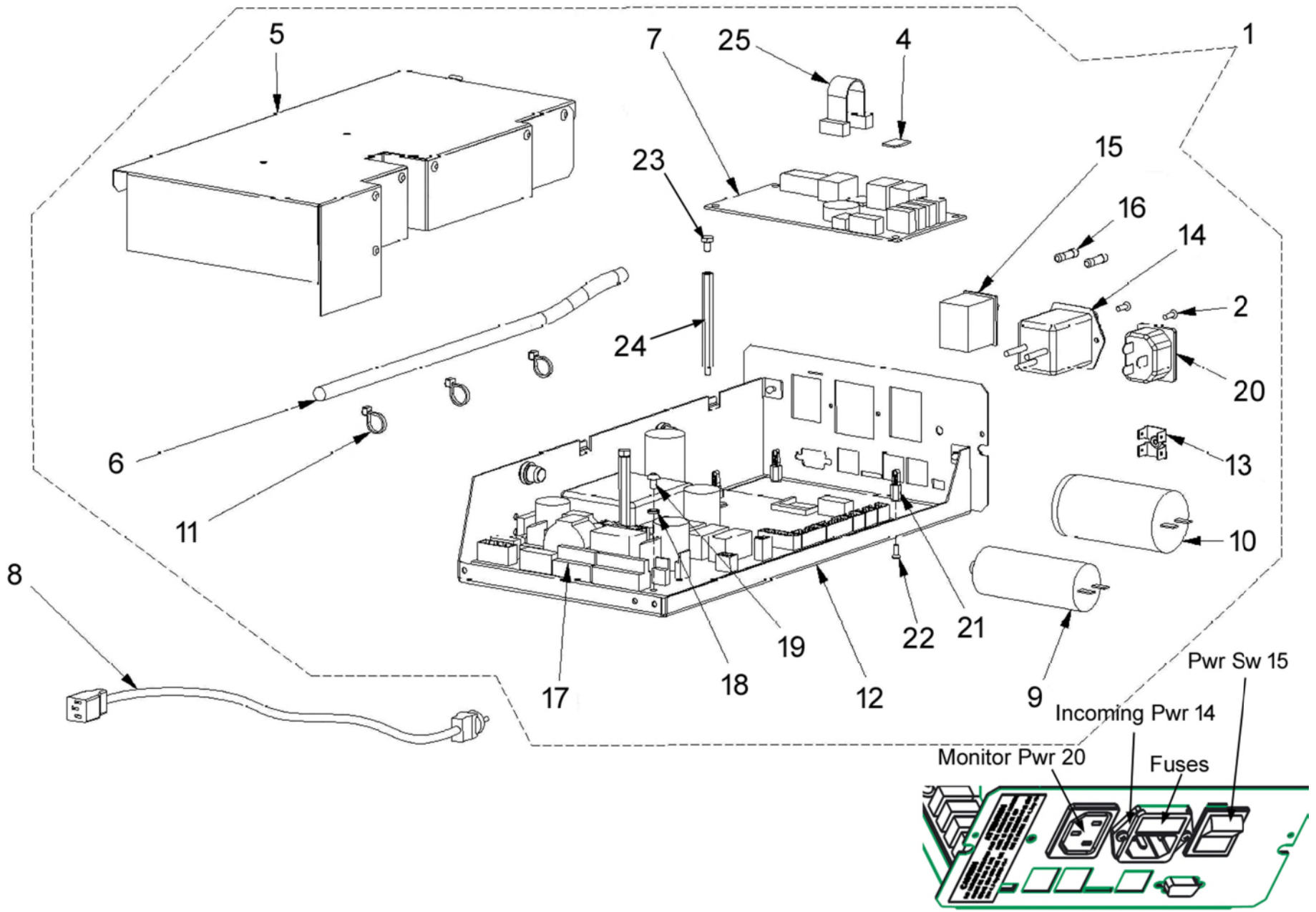

Ref	Qty	Part Number	Description
1	1	EAA0507G82AC	E-Box
2	2	1-23223A	Self Tapping Screw
4	1	3-74926AF1	Programmed Micro Sd Card
5	1	EAS2125J94A	Cover Plate
6	1	EAW0282G97A	Main Cable
7	1	EAP0276G60A	EPC Board
8	1	EAX0039J01A	Power Supply Cable 230 V
9	1	2-01429A	Capacitor 10 Mfd
10	1	2-01529A	Capacitor 20 Mfd
11	3	5-845	Cable Tie, Plastic
12	1	EAA0423J18A	Frame For IBP + EPC
13	1	2-23201	Flat Plug Grounding 4-Pol.
14	1	2-64948A	Filtered Input Module
15	1	2-13258A	Main Switch
16	2	2-21251A	6.3 Amp Time Delay Fuse
17	1	EAP0290G00A	IBP Board
18	5	1-5547	Washer
19	5	1-19804	Screw, Phil Pan Head M4 x 6
20	1	2-63348A	Outlet For External Monitor
21	4	2-09632A	PCB Spacer
22	4	1-20203A	Screw M3 x 8
23	2	1-27101A	Hex Head Screw
24	2	1-16561A	Spacer
25	1	EAW0283G15A	EPC Power Supply Cable

Electronic Box used from 10/2023 (766KSxxx)

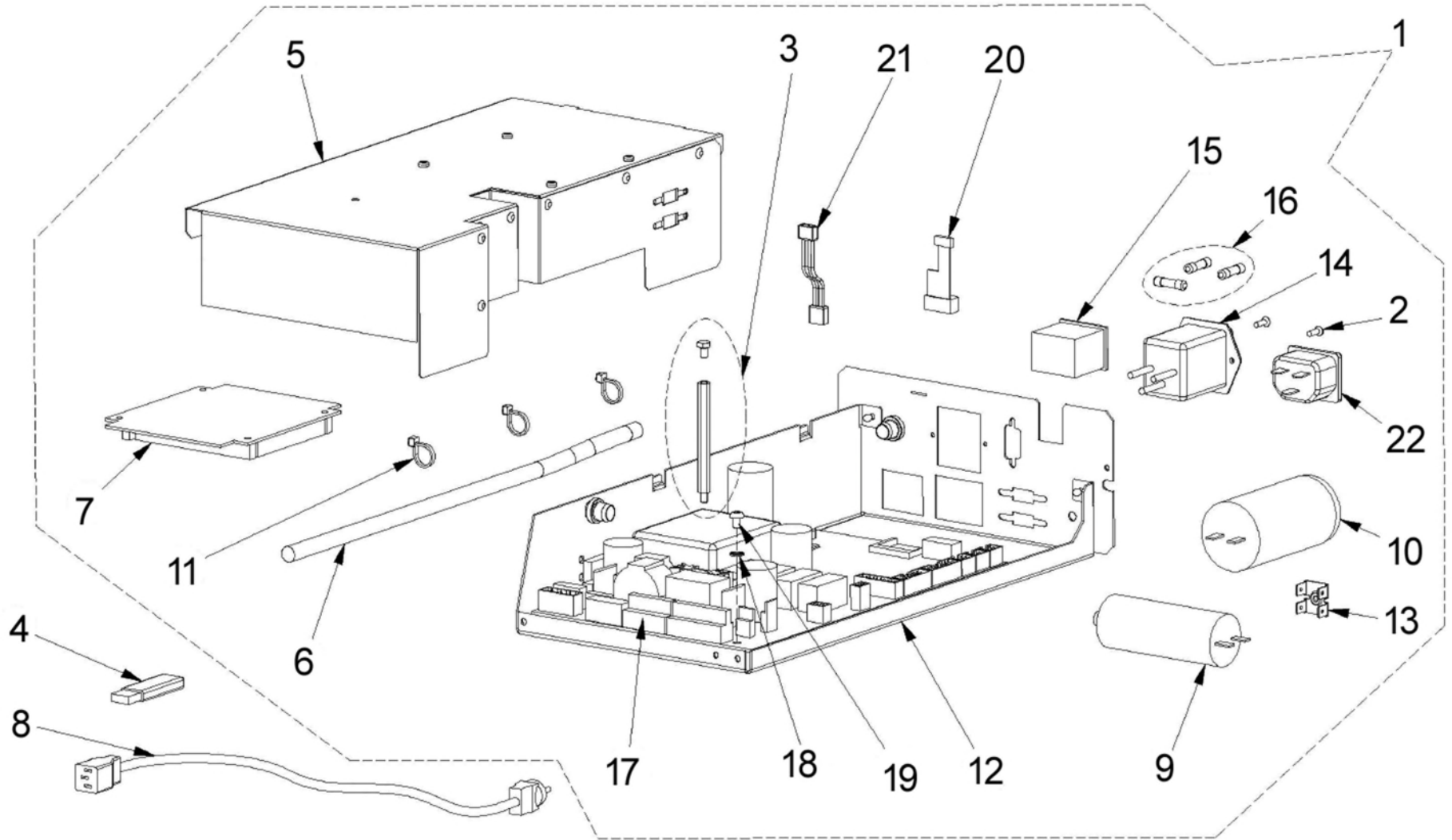

Ref	Qty	Part Number	Description
1	1	EAA0537G76A	E-Box
2	2	1-23123A	Screw
3	1	EAK0390G28A	Kit Spacer / Screw
4	1	3-20129AP1	Programmed USB Stick
5	1	EAS2269G18A	Cover Plate
6	1	EAW0287G79A	Main Cable
7	1	3-09609A	EPC Board - PCM3365E
8	1	EAX0039J01A	Power Supply Cable
9	1	2-01429A	Capacitor 10 mfd
10	1	2-01529A	Capacitor 20 mfd
11	3	5-845	Cable-Tie, Plastic
12	1	EAA0537G77A	Frame For IBP + EPC
13	1	2-23201	Flat Plug Grounding 4-Pol.
14	1	2-64948A	Filtered Input Module
15	1	2-13258A	Main Switch
16	1	EAK0315G59A	Kit Fuses
	3	2-21251A	6.3 Amp Time Delay Fuse
17	1	EAP0290G00A	IBP Board
18	6	1-5547	Contact Washer
19	6	1-19804	Screw
20	1	EAW0287G77A	Serial Com. Cable
21	1	EAW0287G76A	EPC Supply Cable
22	1	2-63348A	Connector AC Outlet (IEC 320)

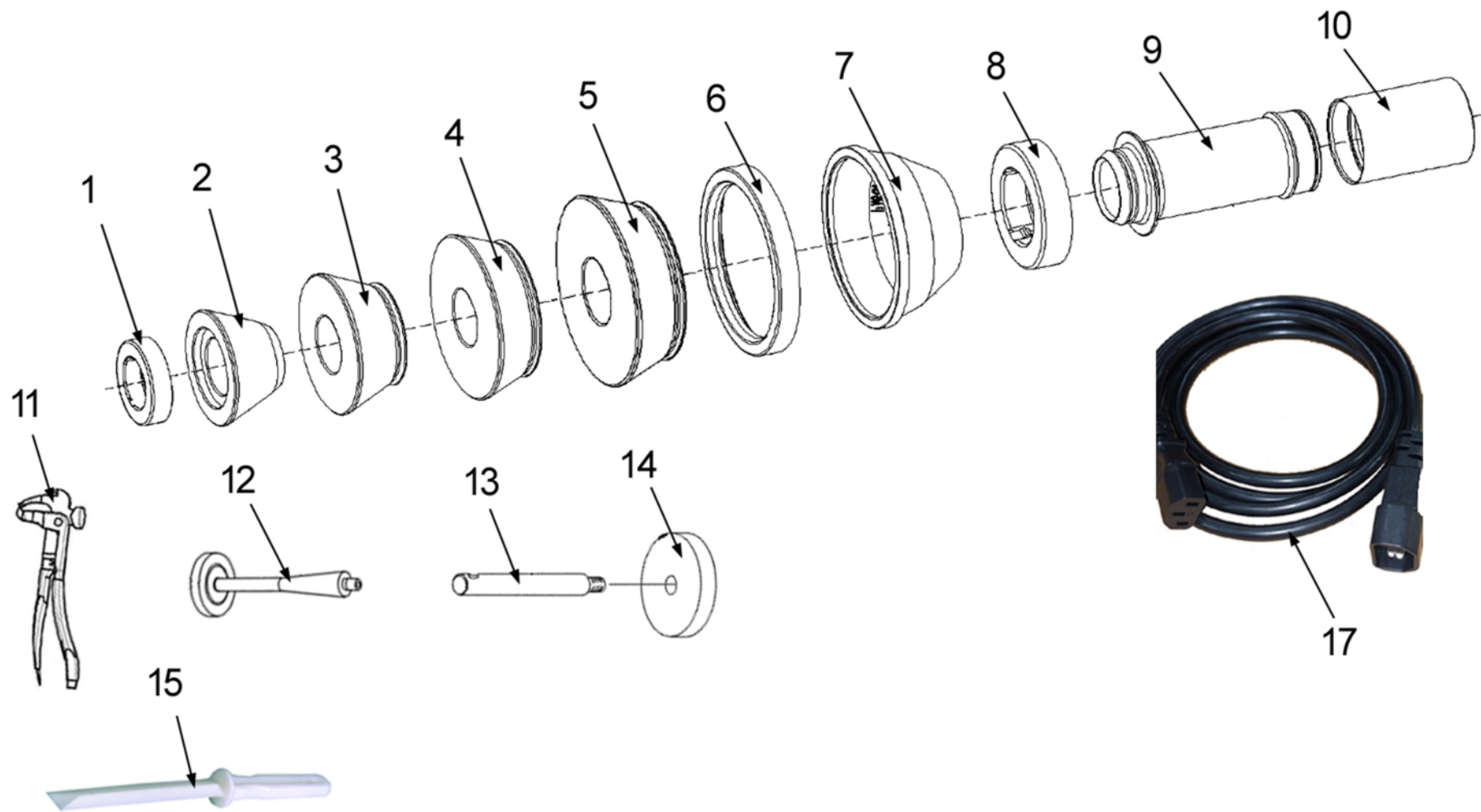

Ref	Qty	Part No	Description
1	1	EAC0058D08A	Pressure Ring
2	1	EAM0005D23A	Cone 1.65" - 3.03"
3	1	EAM0005D24A	Cone 2.83" - 3.9"
4	1	EAM0005D25A	Cone 3.78" - 4.57"
5	1	EAM0003J69A	Cone 3.42" - 5.25"
6	1	EAC0058D15A	Rubber Protection Ring
7	1	EAC0058D07A	Pressure Cup
8	1	EAC0058D08A	Pressure Ring
9	1	EAM0086G86A	Clamping Sleeve P-Version L
10	1	EAC0058D69A	Protection Sleeve Long
11	1	00058839000	Pliers, Wheel Weights
12	1	EAM0005D40A	Calibration Weight
13	4	EAM0006G01A	Hook
14	4	EAC0060G02A	Flanges Guard
15	1	EEHT300A	Tool
17	1	EAW0286G19A	Monitor Power Cord



Notice: The information contained in this document is subject to change without notice. Hofmann makes no warranty with regard to this material. Hofmann shall not be liable for errors contained herein or for incidental consequential damages in connection with furnishings, performance, or use of this material.

309 Exchange Ave
Conway, AR 72032
501-450-1500

Geodyna 8200p Spare Parts List - EEWB766BEA

TEEWB766BEA3_TS

DSS

03/2024